

Parts

GX-7A Assembly

295542, 295543, 295544, 295545

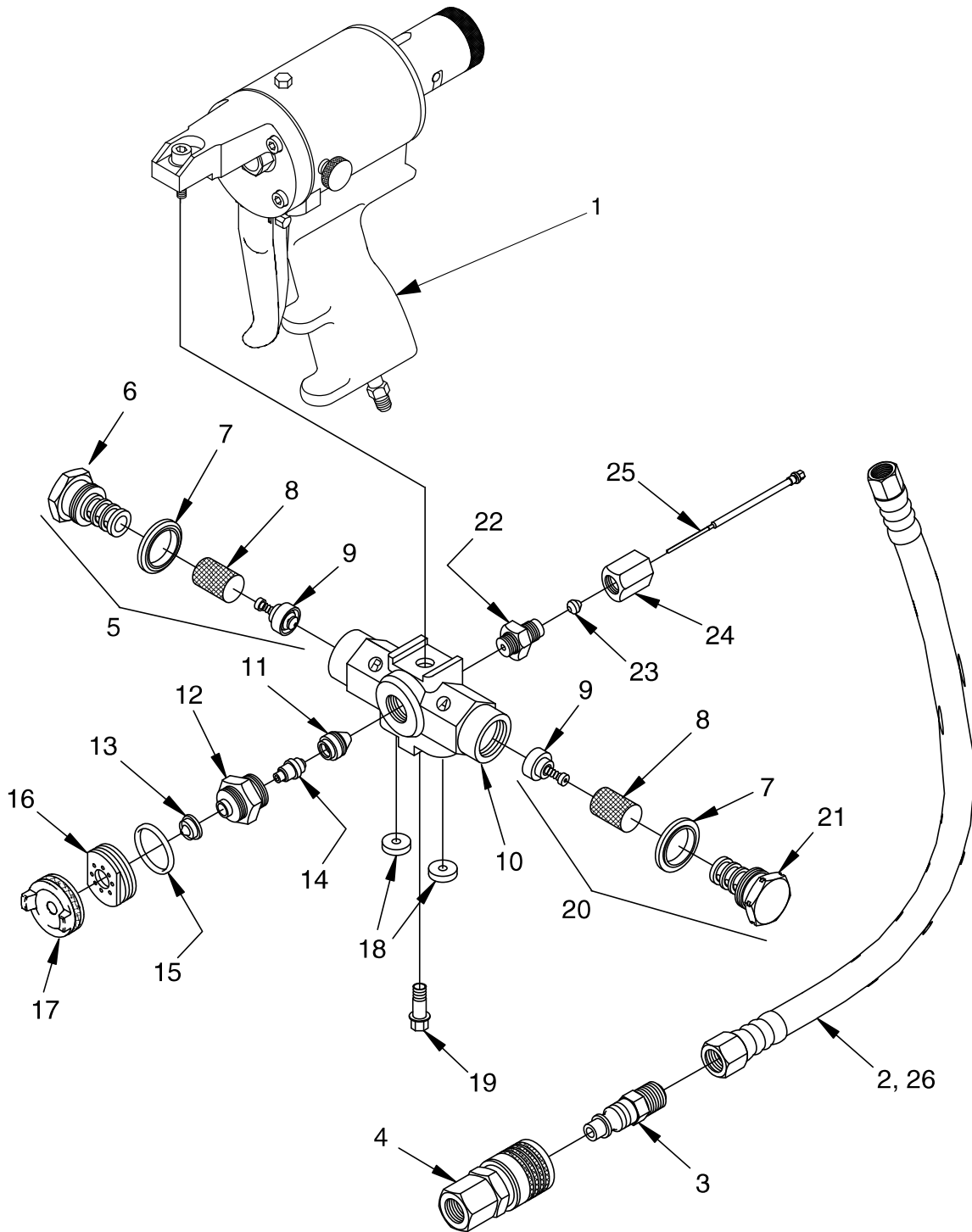

GX-7A Assembly**295542, 295543, 295544, 295545**

Ref. Part	Description	Qty.
1	295810 Spray gun handle	1
2	15B772 Air hose	1
3	295596 Coupler plug	1
4	295597 Coupler	1
5	296834 R-gun block screen screw assembly (includes 6, 7, 8, 9)	1
6	R-gun block screen screw	1
7	296693 Screen screw seal (pack of 2)	-
	296723 Screen screw seal (pack of 10)	-
8	296792 Screen, 80 mesh (pack of 10)	-
	296724 Screen, 80 mesh (pack of 50)	-
9	296722 Check valve assembly (pack of 10)	-
10	295384 Gun block	1
11	Module; see GX-7A Mix Module Kit , page 45	1
12	296976 PCD body	1
13	Tip; see Tip Kits , page 50	1
14	296978 Front packing (pack of 5)	1
15	295868 O-ring	1
16	296832 PCD retainer	1
17	296831 Air cap	1
18	296128 Coupling block gasket (pkg 2)	1
19	295433 Coupling block mounting screw	1
	296979 Coupling block mounting screw kit (pack of 2)	-
20	296833 A-gun block screen screw assembly (includes 6, 8, 9, 21)	1
21	A-gun block screen screw	1
22	296828 Rear packing retainer	1
23	296829 Rear seal packing (pack of 5)	-
24	296830 Rear seal retainer	1
25	16K136 Valving rod	1
26	100030 Fitting	1

GX-7 DI Assembly (295541)

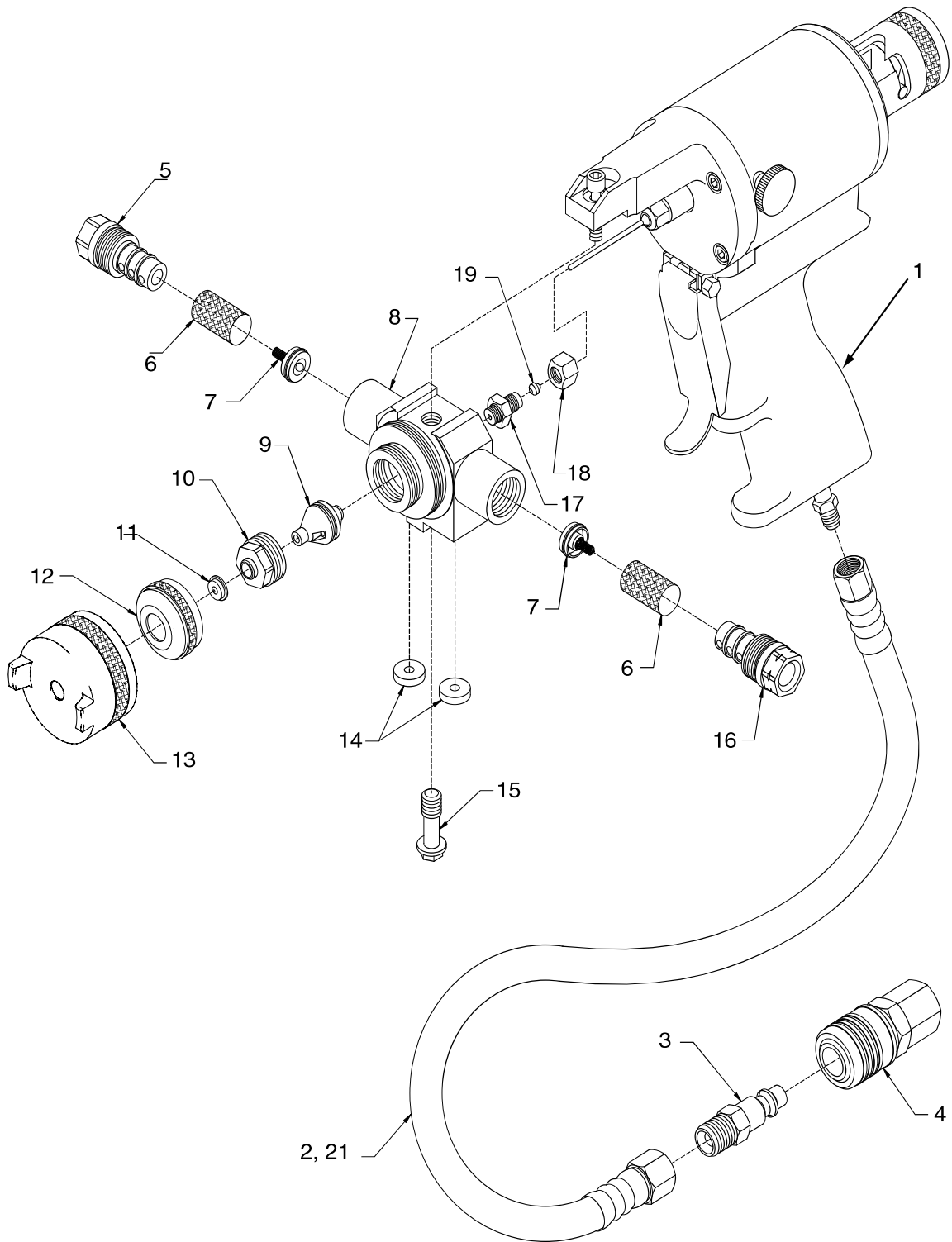

GX-7 DI Assembly (295541)

Ref. Part	Description	Qty.
1	295809 Spray gun handle assembly	1
2	15B772 Air hose, 1/4 in. x 23 in. (FXF)	1
3	295596 Coupler plug	1
4	295597 Coupler	1
5	295835 R-screen screw	1
6	296792 Screen, 80 mesh (pack of 10)	-
	296724 Screen, 80 mesh (pack of 50)	-
7	296713 Check valve assembly (pack of 2)	2
8	295860 Gun block	1
9	Module; see GX-7 DI Model Specifications , page 49	1
10	295837 Module retainer	1
11	Tip; see Tip Kits , page 50	1
12	296865 Tip retainer	1
13	295838 Air cap	1
14	296128 Coupling block gasket (pack of 2)	-
15	295433 Coupling block mounting screw	1
	296979 Coupling block mounting screw (pack of 2)	-
16	295834 A-screen screw	1
17	295836 Rear seal gland	1
18	296864 Rear seal retainer assembly	1
19	296829 Rear seal packing (pack of 5)	-
20	295383 Coupling block (not shown)	1
21	100030 Fitting	1

GX-7 400 Assembly (295540)

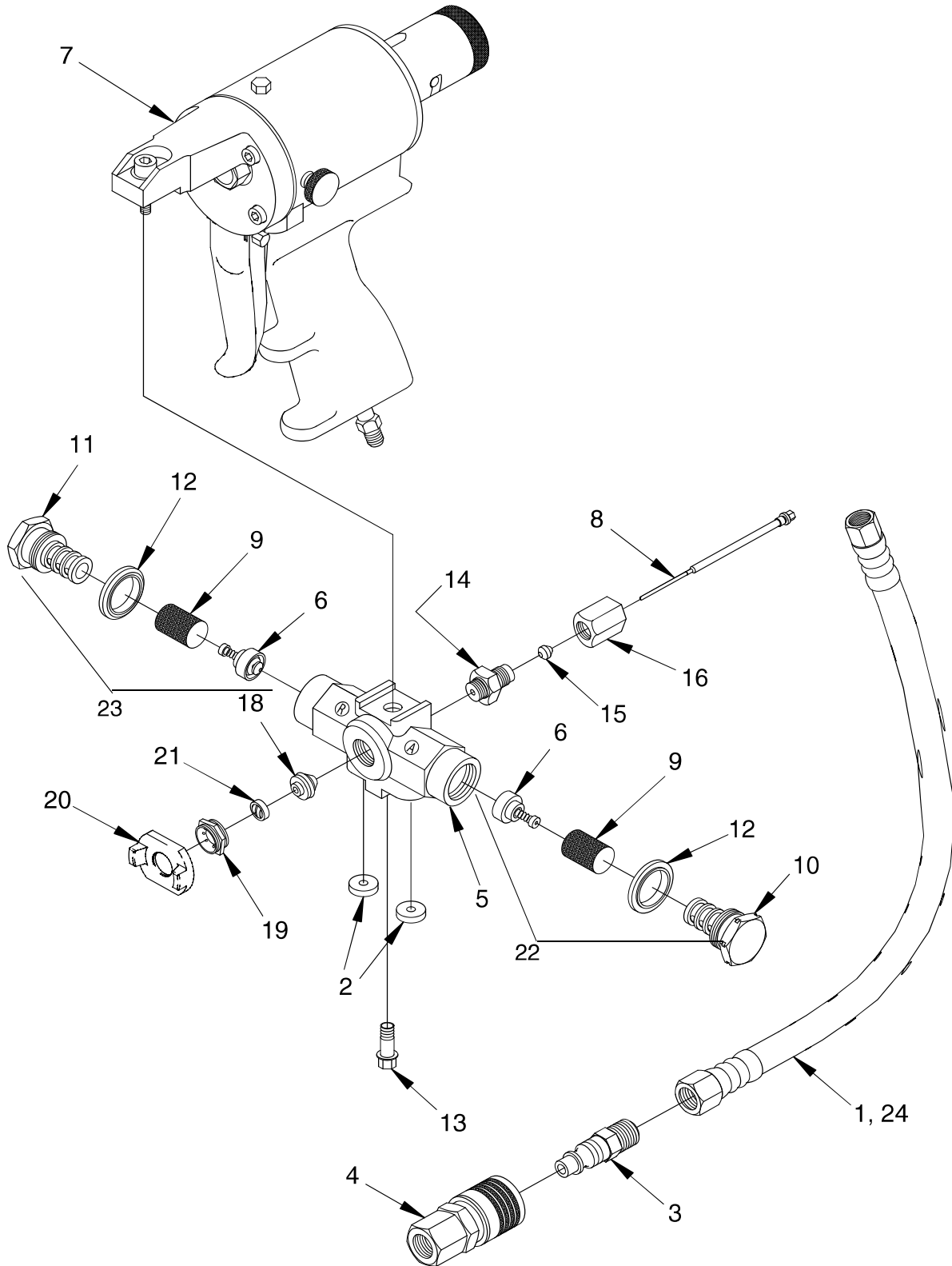

GX-7 400 Assembly (295540)

Ref. Part	Description	Qty.
1 15B772	Air hose	1
2 296128	Coupling block gasket (pack of 2)	-
3 295596	Coupler plug	1
4 295597	Coupler	1
5 295384	Gun block (includes 13)	1
6 296722	Check valve assembly (pack of 10)	-
7 295799	Spray gun handle assembly	1
8 16K136	Valving rod	1
9 296792	Screen-80, mesh (pack of 10)	-
296724	Screen-80, mesh (pack of 50)	-
10	A-Screen screw	1
11	R-Screen screw	1
12 296693	Screen screw seal (pack of 2)	-
296723	Screen screw seal (pack of 10)	-
13 295433	Coupling block mounting screw	1
296979	Coupling block mounting screw kit (pack of 2)	-
14 296828	Rear packing retainer	1
15 296829	Rear seal packing (pack of 5)	1
16 296830	Rear seal retainer	1
18	Module; see GX-7 400 Mix Module Kit , page 47	1
19 296836	Retainer	1
20 296837	Air cap	1
21	Tip; see Tip Kits , page 50	1
22 296833	A-gun block screen screw assembly (includes 6, 9, 10, 12)	-
23 296834	R-gun block screen screw assembly (includes 6, 9, 10, 12)	-
24 100030	Fitting	1

GX-7A Handle (24K734)

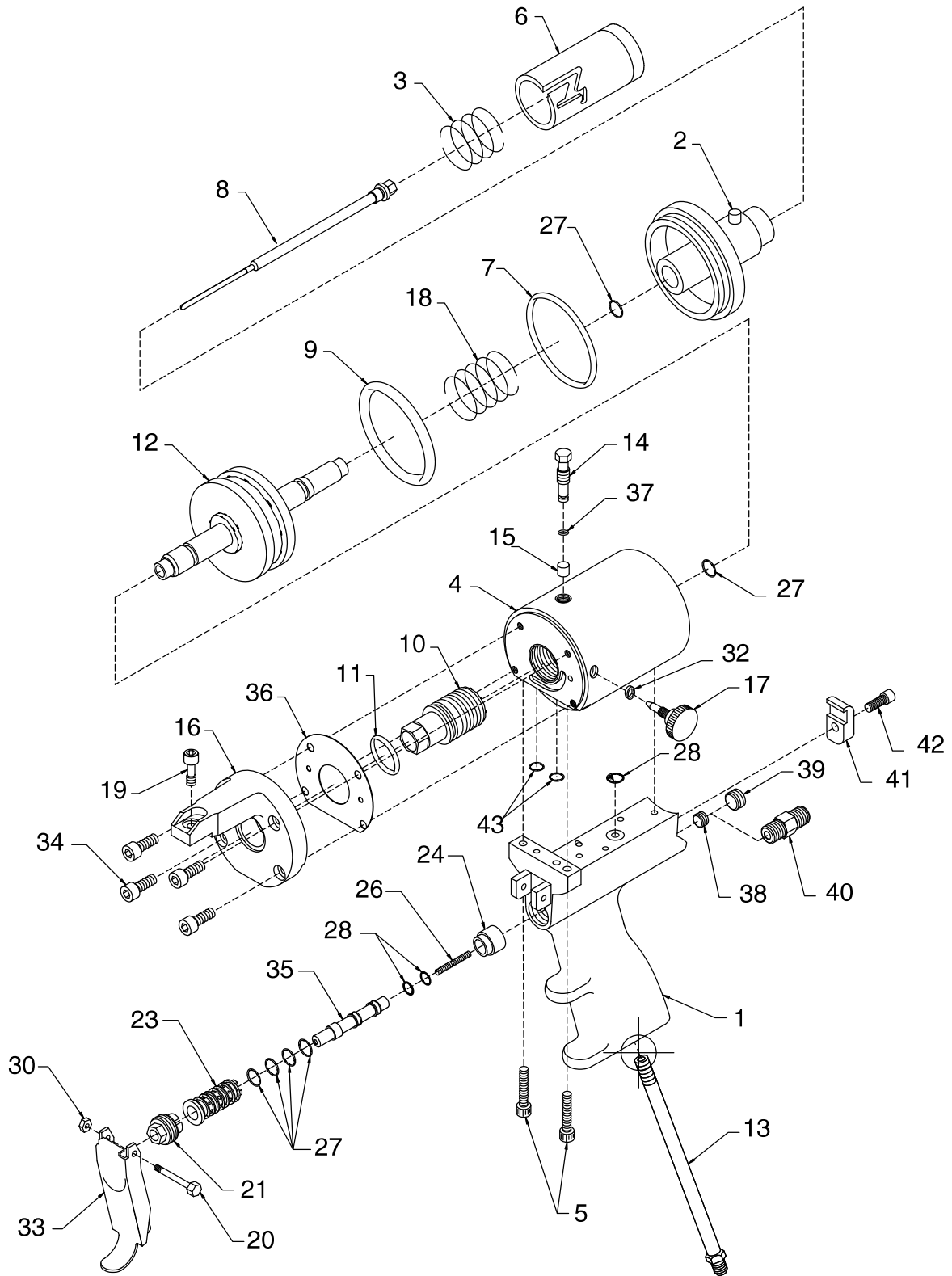

GX-7 Handle (24K734)

Ref.	Part	Description	Qty.	
1	296862	Spray gun handle	1	† Parts included in Handle Seal Rebuild Kit 296895 (purchase separately).
2	295678	Cylinder end cap assembly	1	* Parts included in Trigger valve rebuild kit 296897 (purchase separately).
3	295676	Spring	1	
4	295675	Air cylinder	1	
5	295709	Socket head cap screw, 8-32 x 3/4 in.	2	◆ Valving rod 16K136 is shipped loose.
6	295680	Two position stop	1	
7†	295681	O-ring	1	
8◆	16K136	Valving rod	1	
9†	295683	O-ring	1	
10	295663	Cylinder front stop	1	
11†	514279	O-ring	1	
12	295664	Air piston assembly	1	
13	295665	Pipe nipple	1	
14	295666	Stop clamp screw	1	
15†	295667	Nylon pellet	1	
16	295673	Gun block mount	1	
17	295677	Air needle valve	1	
18	295668	Spring	1	
19	295669	Socket head cap screw, 1/4-28 x 5/8	1	
20	295671	Trigger mounting screw	1	
21	295688	Valve nut	1	
23	295686	Spool valve liner	2	
24	295689	Spring seat	1	
26*	296971	Air valve spring	1	
27†*	106555	O-ring	6	
28†*	C20988	O-ring, fluoroelastomer	3	
30	295438	Locknut, elastic stop nut, 5-40	1	
32†	295405	Needle valve packing	1	
33	295692	Spray gun trigger	1	
34	295684	Socket head cap screw, 10-32 x 1/2	4	
35	295687	Spool valve	1	
36†	295674	Gasket	1	
37†	295706	O-ring, Neoprene	1	
38	295693	Pipe plug, flush seal, 1/6 NPT	1	
39	295662	Pipe plug, flush seal, 1/8 NPT	1	
40	103656	Hex nipple, 1/8 NPT (optional)	1	
41	295690	Cylinder clamp	1	
42	C20003	Socket head cap screw, 10-32 x 1/2	1	
43†	295685	O-ring	2	

GX-7 DI Handle (295809)

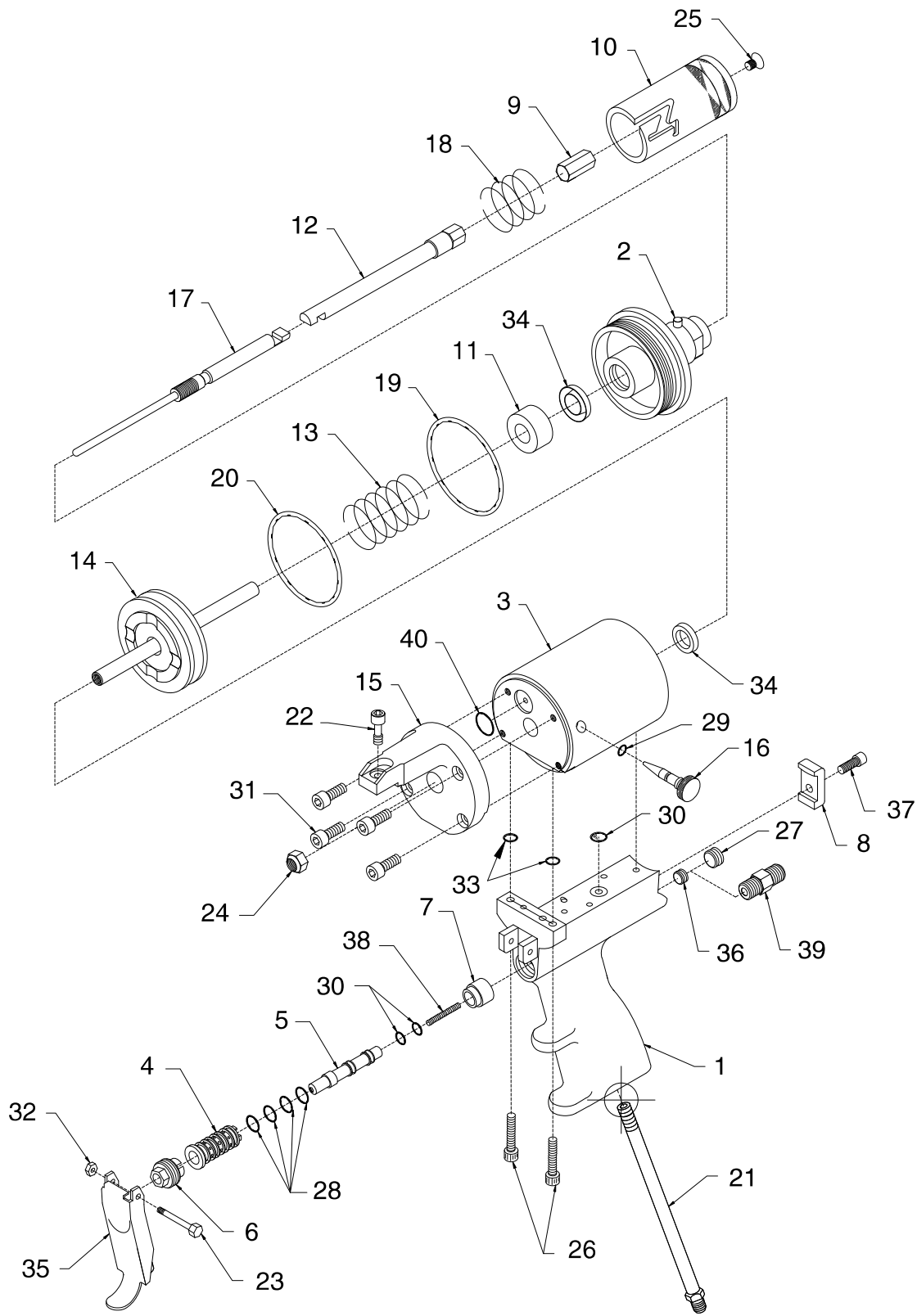

GX-7 DI Handle (295809)

Ref.	Part	Description	Qty.
1	296862	Gun handle	1
2	295714	Cylinder end cap assembly	1
3	295715	Air cylinder	1
4	295686	Valve liner	1
5	295687	Valve spool	1
6	295688	Valve retainer nut	1
7	295689	Spring seat	1
8	295690	Cylinder clamp	1
9	295716	Stop, stroke, long	1
10	295717	Two position stop body	1
11	295718	Stroke spacer	1
12	296736	Valving rod holder kit	1
13	295720	Piston spring	1
14	295712	Piston assembly	1
15	295721	Gun block mount	1
16	295713	Air needle valve	1
17	296863	Valving rod, 125 SS	1
18	295676	Spring	1
19†	295681	O-ring	1
20†	295683	O-ring	1
21	295665	Pipe nipple	1
22	295669	Socket head cap screw, 1/4-28 x 5/8	1
23	295671	Trigger mounting screw	1
24	295431	Locknut	1
25	295722	Flat head cap screw, 10-32 x 1/4 in.	1
26	295709	Socket head cap screw, 8-32 x 3/4 in.	2
27	295662	Pipe plug, flush seal, 1/8 in.	1
28*	106555	O-ring, fluoroelastomer	4
29†	C20988	O-ring, fluoroelastomer	1
30†*	103337	O-ring, fluoroelastomer	3
31	295684	Socket head cap screw, 10-32 x 5/8 in.	4
32	295438	Stop nut, elastic	1
33†	295685	O-ring	2
34†	295496	U-cup	2
35	295692	Trigger	1
36	295693	Pipe plug, flush seal, 1/16 in.	1
37	C20003	Socket head cap screw, 10-32 x 1/2	1
38*	295442	Spring	1
39	103656	Hex nipple (optional), 1/8 MPT	1
40†	103338	O-ring, fluoroelastomer	1

† *Parts included in Air Cylinder Rebuild Kit
296895 (purchase separately).*

* *Parts included in Trigger Valve Rebuild Kit
296897 (purchase separately).*

GX-7 400 Handle (24K733)

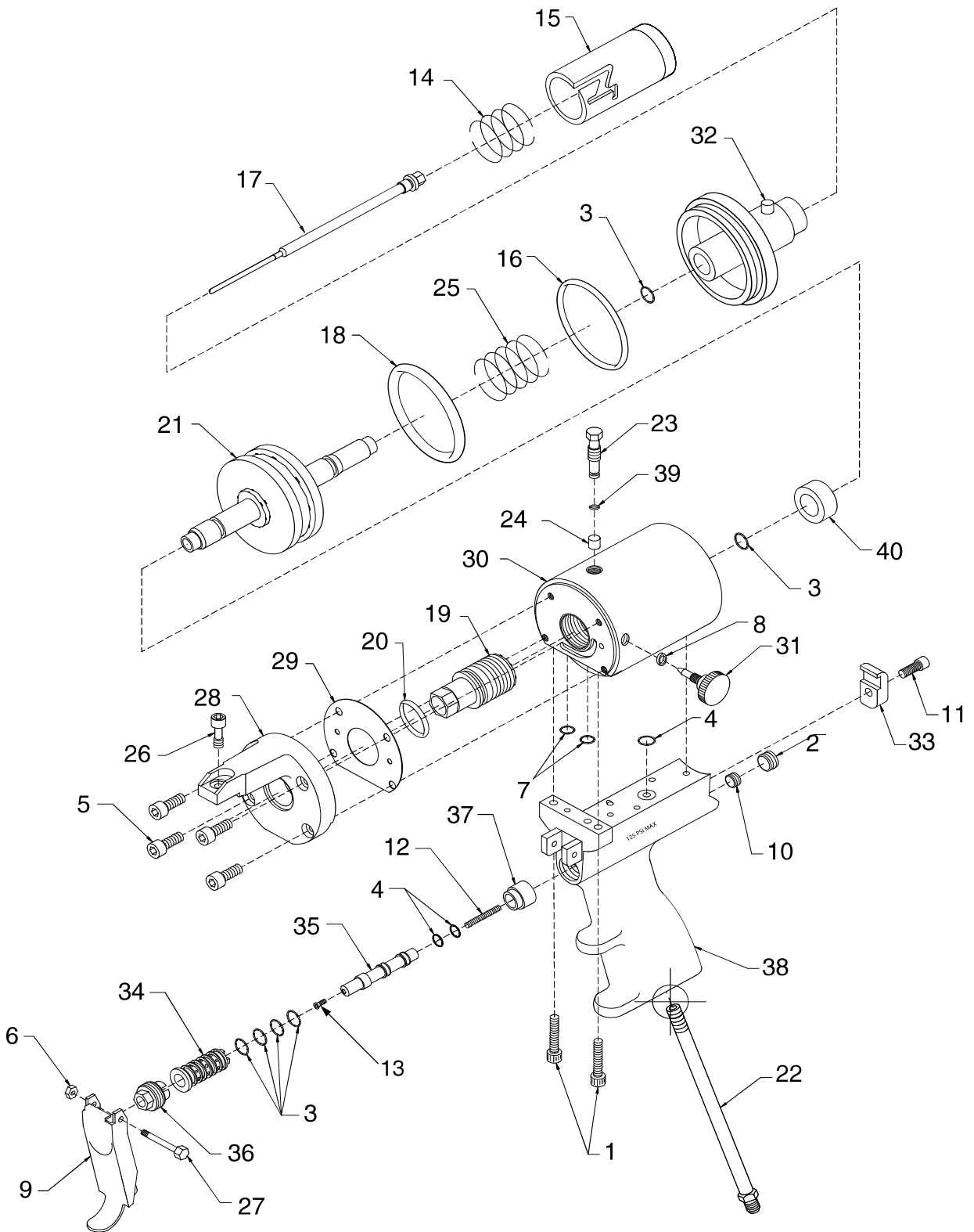

GX-7 400 Handle (24K733)

Ref.	Part	Description	Qty.
1	106245	Cap screw, SCH	2
2	295662	Pipe plug	1
3†*	106555	Packing o-ring	6
4†*	103337	Packing o-ring	3
5	295684	Socket head cap screw	4
6	295438	Stop nut, elastic, 5-40	1
7†*	295685	O-ring	2
8†	295405	Needle valve, packing	1
9	295692	Spray gun trigger	1
10	295693	Pipe plug	1
11	C20003	Socket head cap screw	1
12*	295442	Spring	1
13	295695	Button head cap screw	1
14	295676	Spring	1
15	295771	Two-position stop	1
16†	295681	O-ring	1
17◆	16K136	Valving rod	1
18†	295683	O-ring	1
19	295663	Front cylinder stop	1
20†	514279	O-ring	1
21	295664	Air piston	1
22	295665	Pipe nipple fitting	1
23	295666	Stop clamp screw	1
24†	295667	Pellet	1
25	295668	Spring	1
26	295669	Socket head cap screw, modified	1
27	295671	Trigger mounting screw	1
28	295673	Gun block base	1
29†	295674	Gasket	1
30	295675	Air cylinder	1
31	295677	Air needle valve	1
32	295678	Cylinder end cap	1
33	295690	Cylinder clamp	1
34	295686	Valve liner	1
35	295687	Valve spool	1
36	295688	Retainer valve nut	1
37	295689	Spring seat	1
38	296862	Gun handle	1
39†	295706	O-ring	1
40	295708	Spacer	1

† *Parts included in Air Cylinder Rebuild Kit
296895 (purchase separately).*

* *Parts included in Trigger Valve Rebuild Kit
296897 (purchase separately).*

◆ *Valving rod 16K136 is shipped loose.*

Coupling Block Assembly (295383)

All models

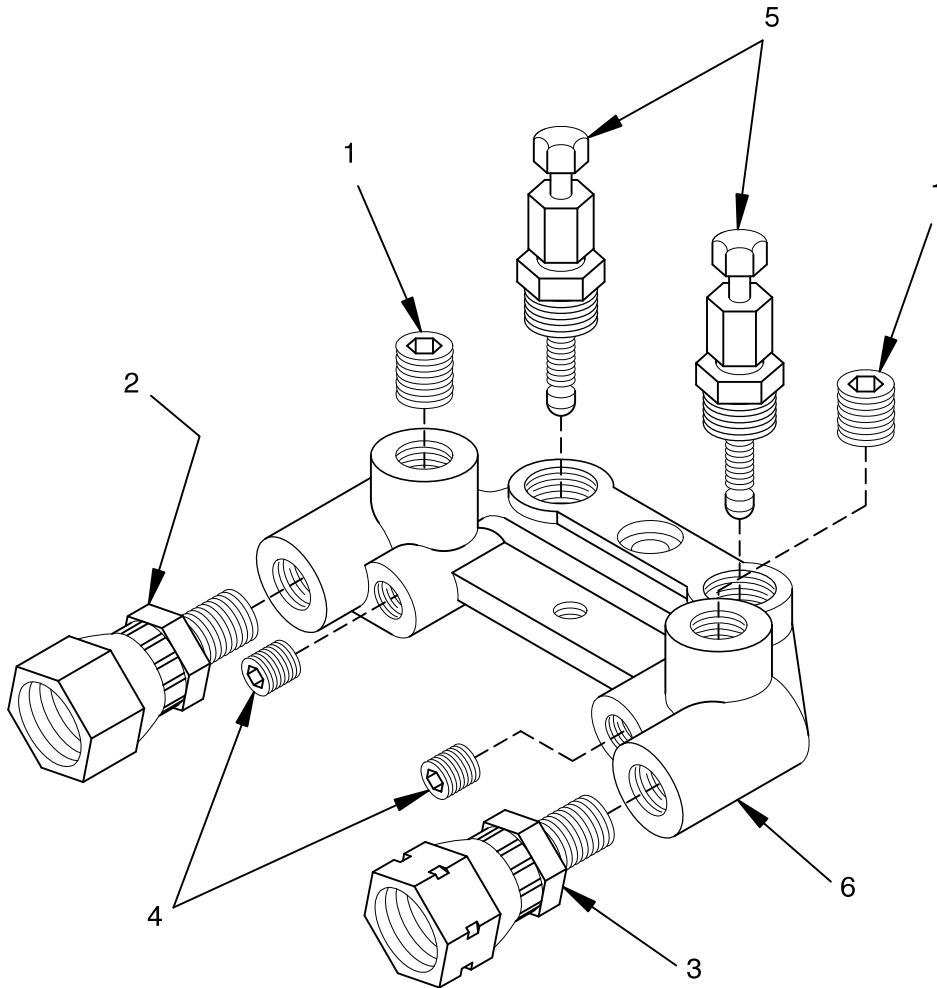

Ref. Part	Description	Qty.	Ref. Part	Description	Qty.		
1	295662	Pipe plug, flush seal, 1/8 in.	2	5	296970	Manual valve assembly	2
2	117634	R-swivel fitting	1	6	296215	Coupling block	1
3	117635	A-swivel fitting	1				
4	295693	Pipe plug, flush seal, 1/16 in.	2				